



US006992616B2

(12) **United States Patent**
Grudkowski et al.

(10) **Patent No.:** **US 6,992,616 B2**
(45) **Date of Patent:** **Jan. 31, 2006**

(54) **MILLIMETER-WAVE ACTIVE IMAGING SYSTEM**

(75) Inventors: **Thomas W. Grudkowski**, Pleasanton, CA (US); **Richard L. Rowe**, Saratoga, CA (US); **Raymond R. Blasing**, Los Altos, CA (US); **Scott T. Trosper**, Meridian, ID (US); **Thomas W. Trawick**, San Jose, CA (US); **Karen A. Meyer**, San Jose, CA (US); **David J. Genske**, Westminster, CO (US); **Gerald J. Van Eyck**, Bothell, WA (US); **Mark D. Brinkerhoff**, San Jose, CA (US)

5,202,692 A	4/1993	Huguenin et al.	
5,227,800 A	7/1993	Huguenin et al.	
5,455,590 A	10/1995	Collins et al.	
5,557,283 A	9/1996	Sheen et al.	
5,760,397 A	6/1998	Huguenin et al.	
5,859,609 A	1/1999	Sheen et al.	
6,057,761 A	5/2000	Yukl	
6,208,288 B1 *	3/2001	Shoucri et al.	342/179
6,437,737 B1 *	8/2002	Azzarelli et al.	342/360
6,507,309 B2	1/2003	McMakin et al.	

(Continued)

OTHER PUBLICATIONS

(73) Assignee: **SafeView, Inc.**, Santa Clara, CA (US)

"Examples of design curves for multirow arrays used with time-shift compensation", Lacefield, J.C.; Waag, R.C. Ultrasonics, Ferroelectrics and Frequency Control, IEEE Trans on vol. 49, Issue 9, Sep. 2002 Ps: 1340-1344.*

(*) Notice: Subject to any disclaimer, the term of this patent is extended or adjusted under 35 U.S.C. 154(b) by 78 days.

(Continued)

(21) Appl. No.: **10/728,456**

Primary Examiner—John B. Sotomayor
(74) *Attorney, Agent, or Firm*—Kolisch Hartwell, P.C.

(22) Filed: **Dec. 5, 2003**

(65) **Prior Publication Data**
US 2005/0122249 A1 Jun. 9, 2005

(57) **ABSTRACT**

(51) **Int. Cl.**
G01S 13/89 (2006.01)
(52) **U.S. Cl.** **342/179; 342/22**
(58) **Field of Classification Search** **342/22, 342/27, 52, 176, 179, 180, 190, 191, 195, 342/197**
See application file for complete search history.

Active millimeter-wave imaging systems can include an antenna apparatus configured to transmit toward and receive from a subject in a subject position, electromagnetic radiation. A controller can include a transceiver configured to operate the antenna apparatus and produce an output representative of the received radiation, and a processor adapted to convert the transceiver output into image data representative of an image of the subject. The antenna apparatus may move in a partial or continuous loop around the subject, toward or away from the subject, or in an opposite direction to an associated antenna apparatus. Antenna units in the antenna apparatus may be oriented at different angular positions along an array. Antenna arrays may also be formed of a plurality of array segments, and a group of arrays may be combined to form an antenna apparatus.

(56) **References Cited**

U.S. PATENT DOCUMENTS

4,901,084 A	2/1990	Huguenin et al.
4,910,523 A	3/1990	Huguenin et al.
4,940,986 A	7/1990	Huguenin
5,047,783 A	9/1991	Huguenin [sic]
5,073,782 A	12/1991	Huguenin et al.
5,170,169 A	12/1992	Stephan

120 Claims, 7 Drawing Sheets

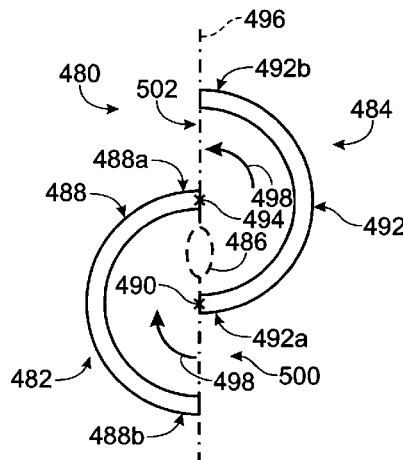

U.S. PATENT DOCUMENTS

6,518,915	B2	2/2003	Schutz et al.	
6,791,487	B1	9/2004	Singh et al.	
2004/0056790	A1	3/2004	Lovberg et al.	
2004/0090359	A1 *	5/2004	McMakin et al.	342/22
2005/0122249	A1 *	6/2005	Grudkowski et al.	342/22
2005/0122257	A1 *	6/2005	Rowe et al.	342/179
2005/0122258	A1 *	6/2005	Blasing et al.	342/179

OTHER PUBLICATIONS

“Real-time 3D imaging using 2D curved array”, Kim, K.S.; Han, H.S.; Chang, S.H.; Song, T.K. Ultrasonics Symposium,

2002. Proceedings. 2002 IEEE vol. 2, Oct. 8-11, 2002 Page(s): 1713-1716.*

U.S. Appl. No. 10/301,552, filed Nov. 21, 2002, McMakin. *The Dielectric People Portal II*, Spatial Guardian Inc., www.spatialguardian.com/products/people_portal/index.shtml.

Transportation Security What Works, Spatial Guardian Inc., www.spatialguardian.com/news_transec_1102.shtml, Nov. 2002.

* cited by examiner

Fig. 1

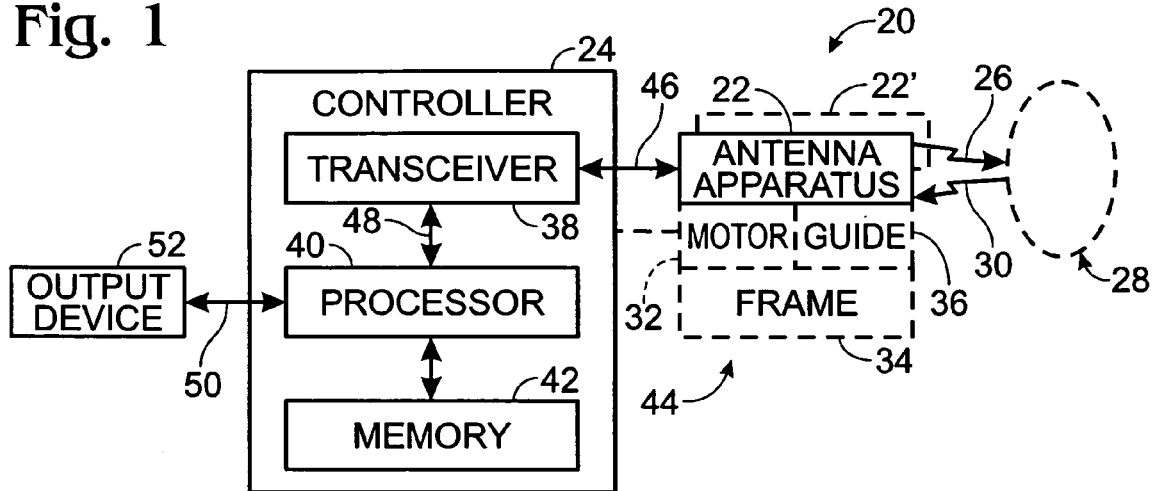

Fig. 2

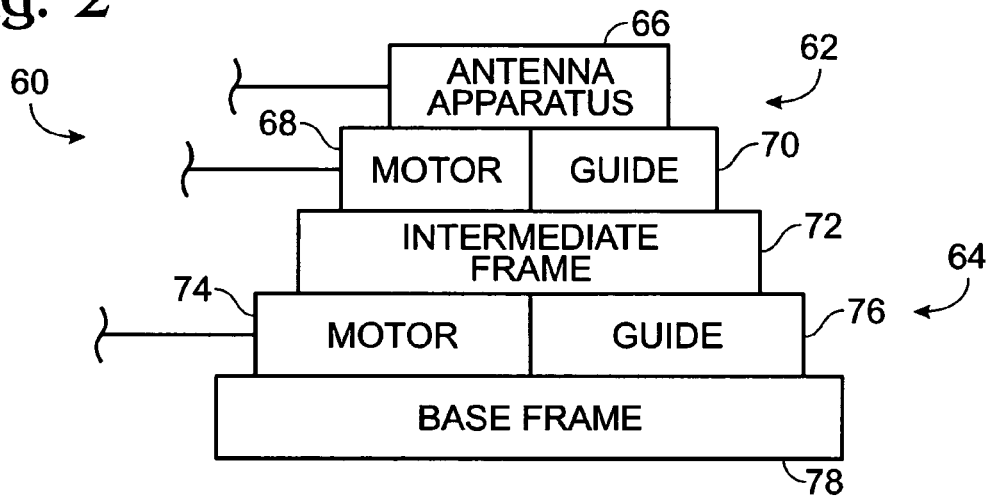

Fig. 3

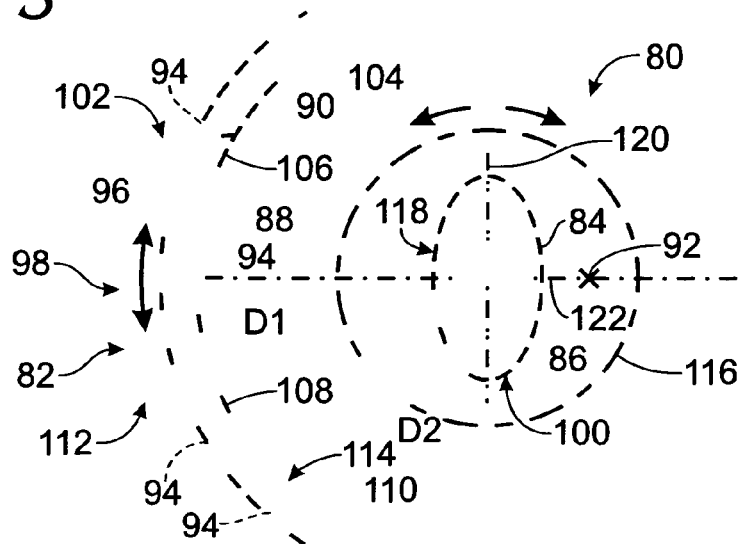

Fig. 4

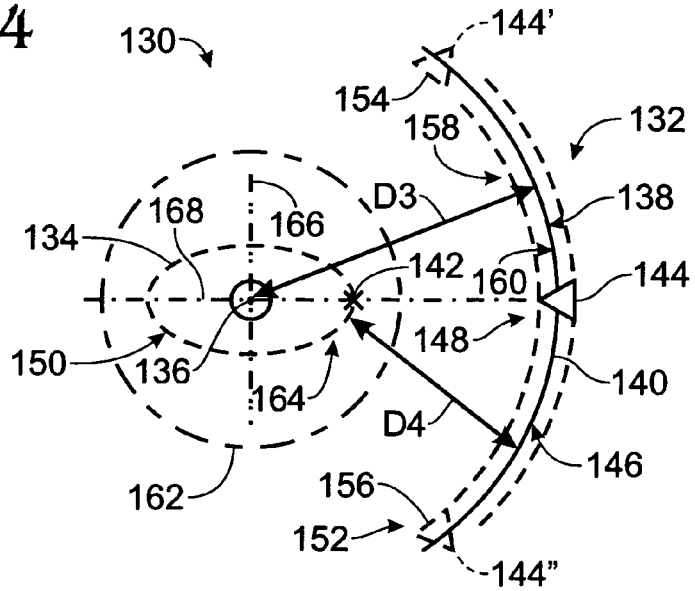

Fig. 5

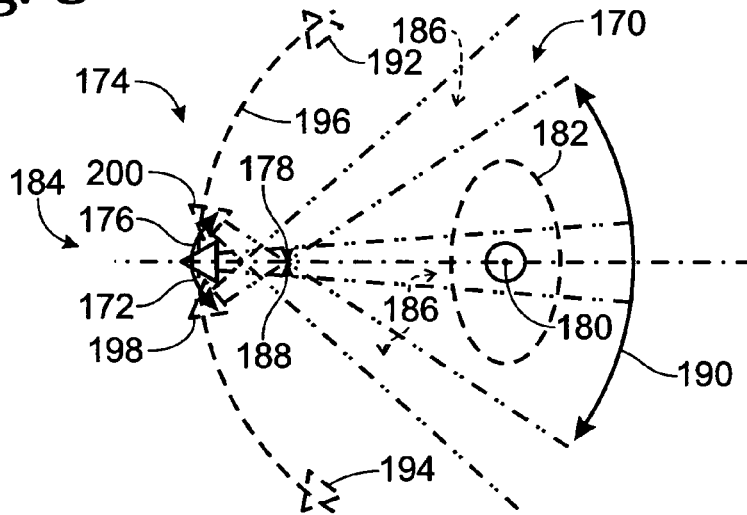

Fig. 6

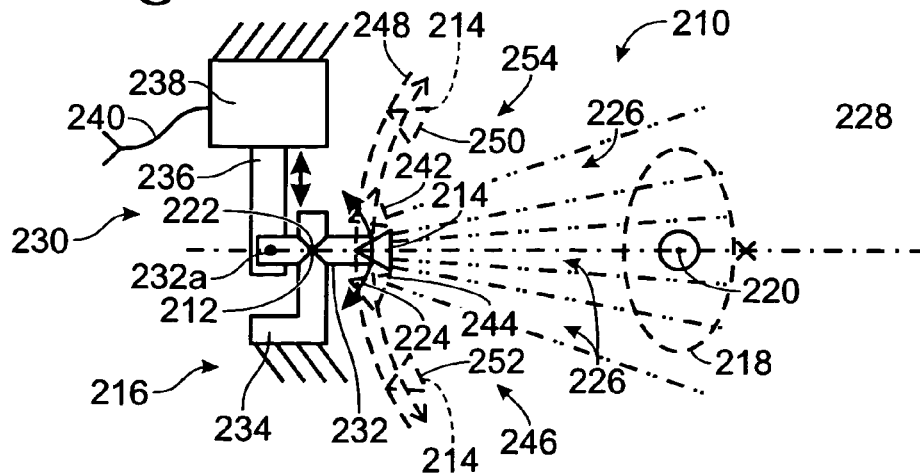

Fig. 7

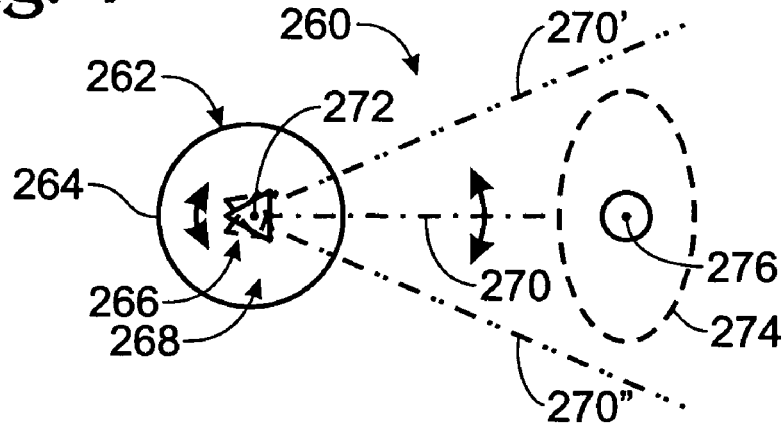

Fig. 8

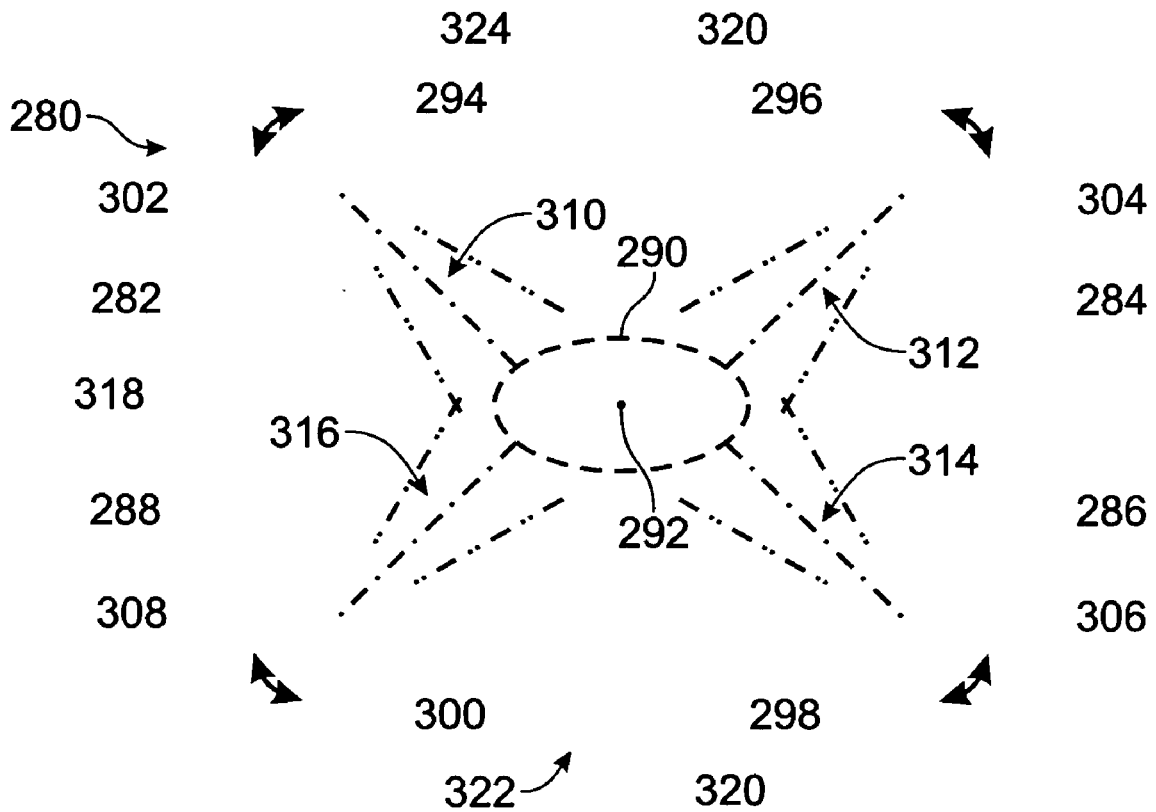

Fig. 9

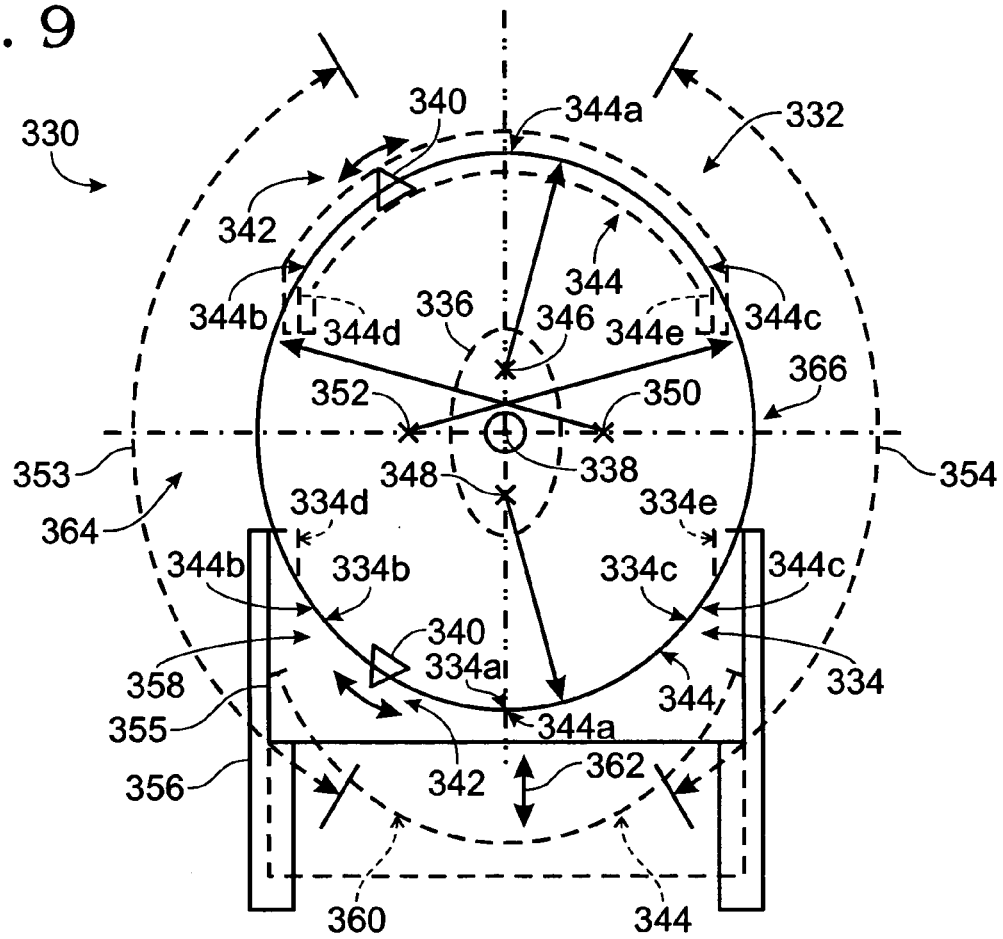

Fig. 10A

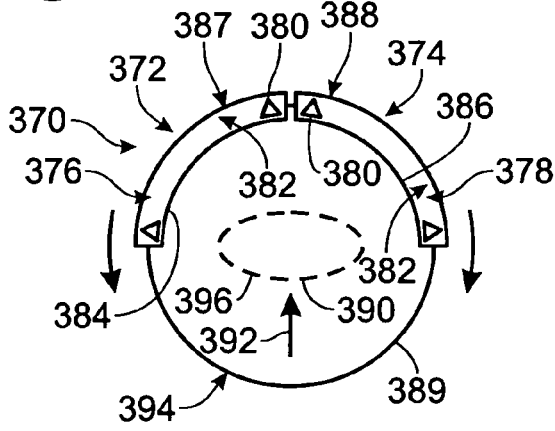

Fig. 13

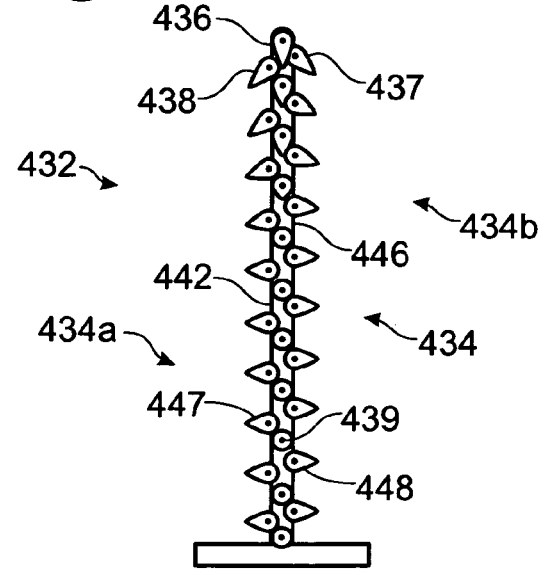

Fig. 10B

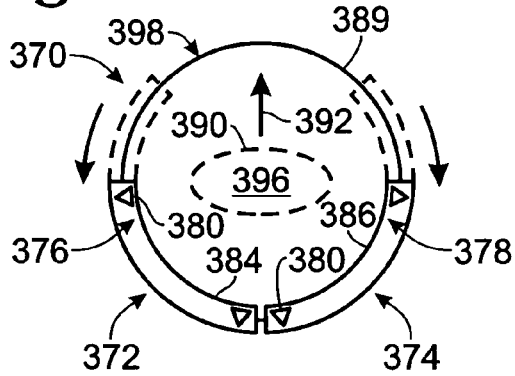

Fig. 10C

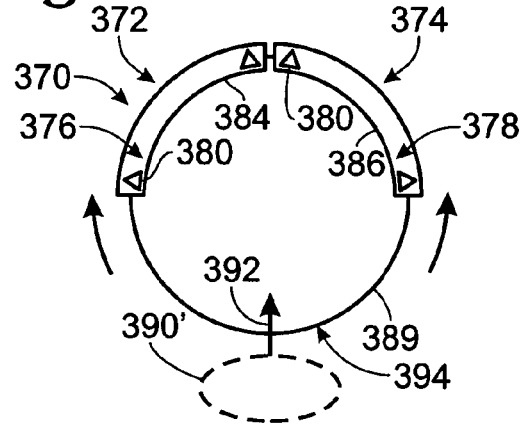

Fig. 11A

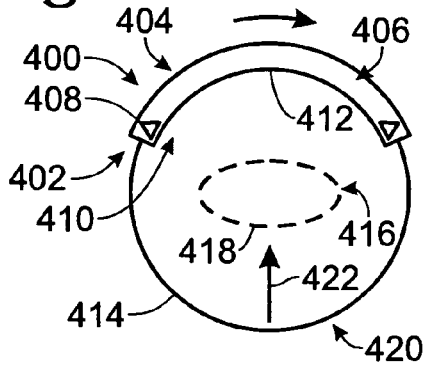

Fig. 11B

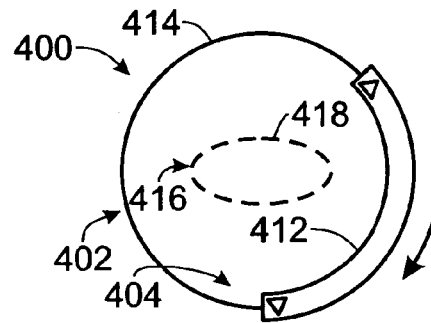

Fig. 11C

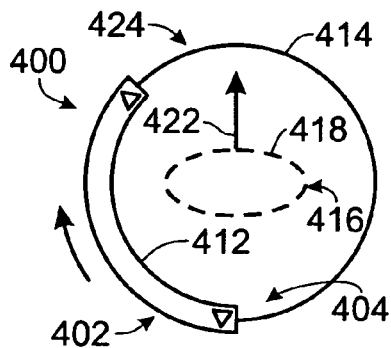

Fig. 11D

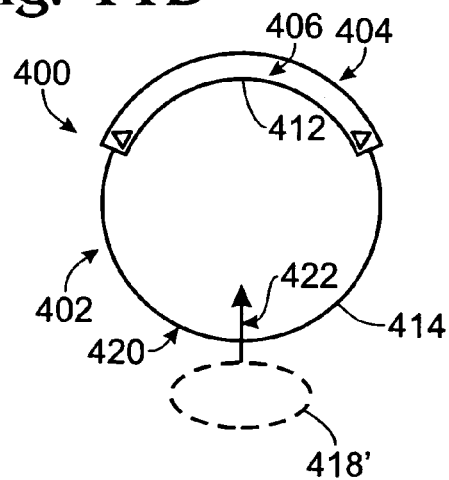

Fig. 12

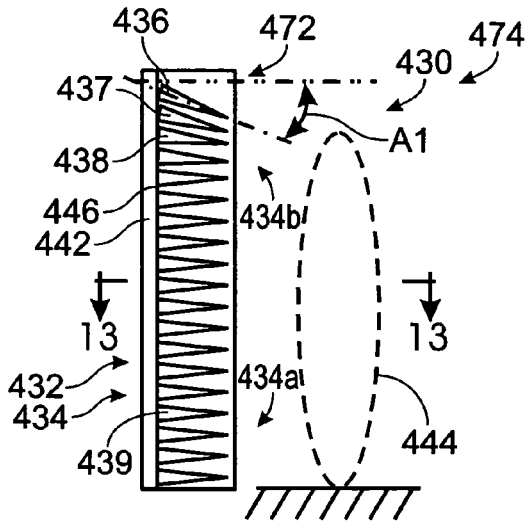

Fig. 14

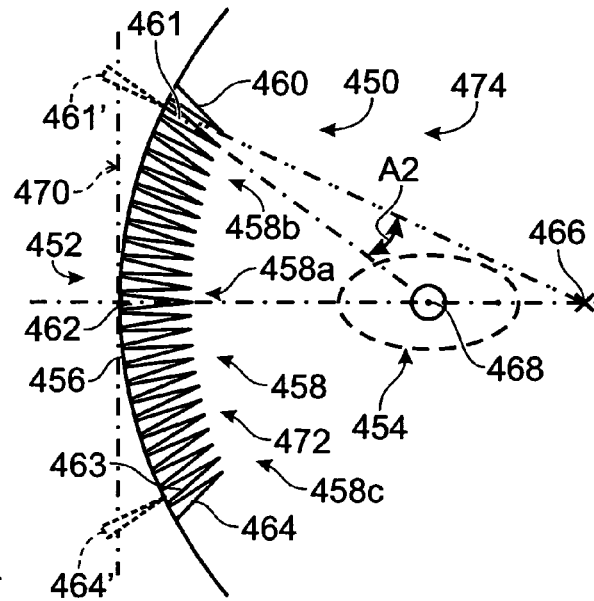

Fig. 15

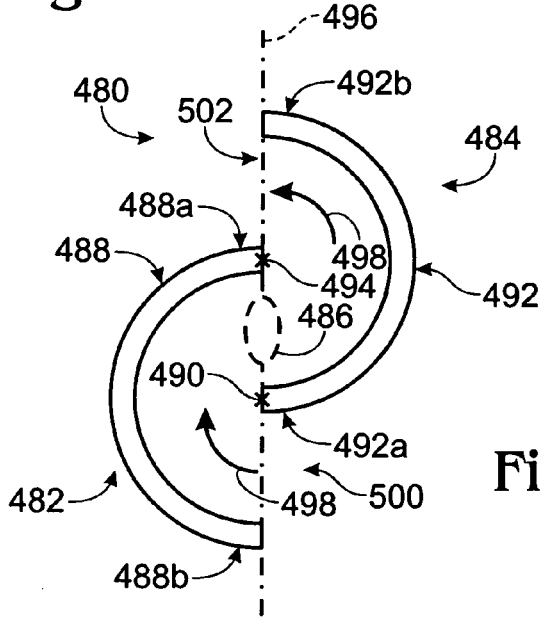

Fig. 18

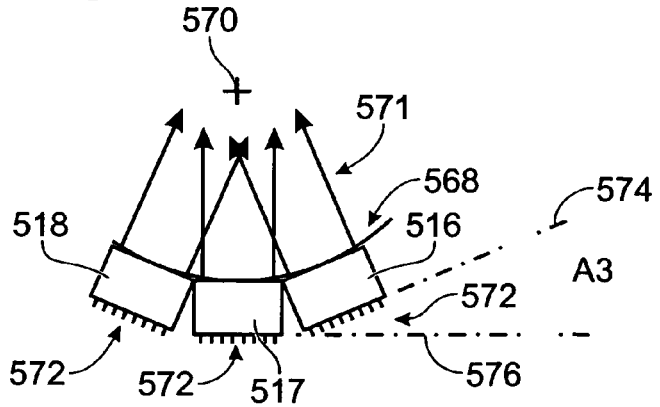

Fig. 16

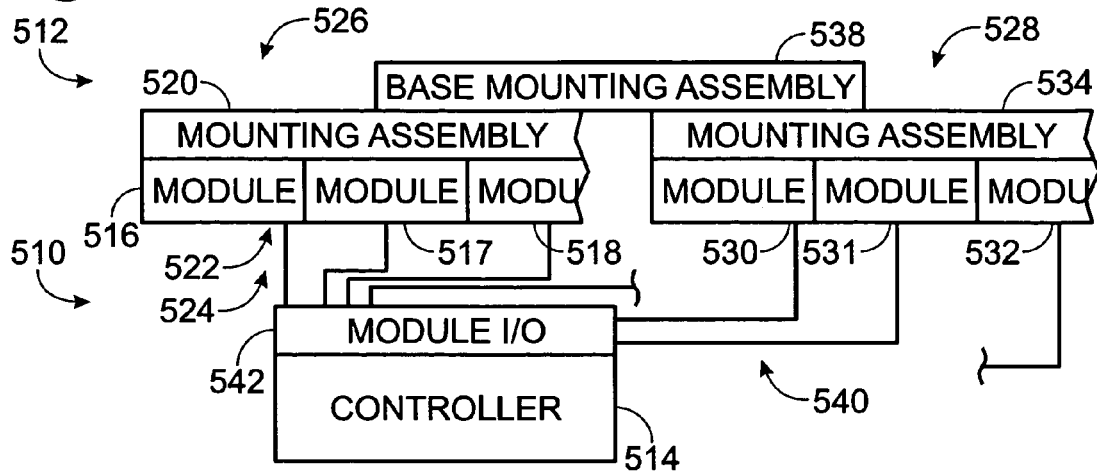

Fig. 17

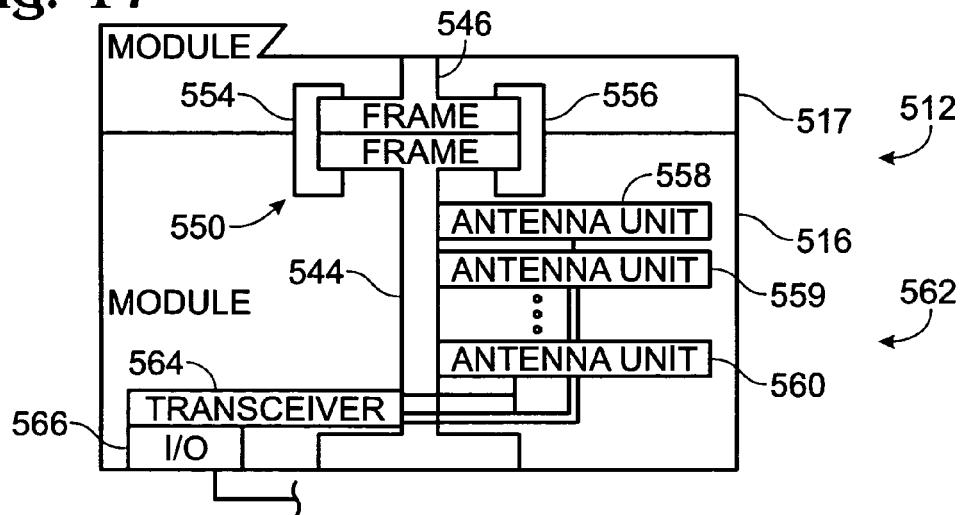

Fig. 19

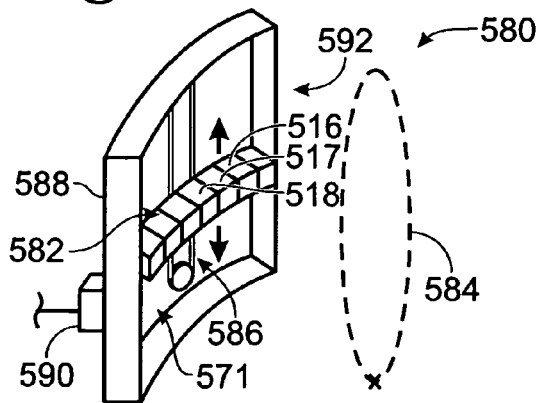
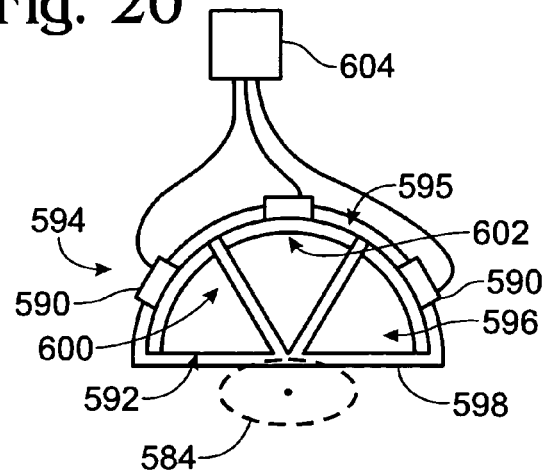

Fig. 20



MILLIMETER-WAVE ACTIVE IMAGING SYSTEM

BACKGROUND

Millimeter wave signals are used for radar and telecommunications. They are also capable of being used for producing an image of a subject by directing millimeter-wave signals at the subject and detecting the reflected signal. Examples of such imaging systems have been described in U.S. Pat. Nos. 5,455,590; 5,557,283; 5,859,609; and 6,507,309; and U.S. patent application Ser. No. 10/607,552 filed Jun. 26, 2003 and a continuation-in-part of that application filed Oct. 30, 2003 entitled "Detecting Concealed Objects at a Checkpoint"; and U.S. patent application Ser. No. 10/301,522 filed Nov. 21, 2002 and a continuation-in-part of that application filed Oct. 30, 2003 entitled "Detection of a Concealed Object", which patent references are incorporated herein by reference.

When imaging systems are used for surveillance of persons, it may be desirable for the system to quickly, conveniently and safely perform the surveillance. This is particularly true in situations where the surveillance delays the intended progress of the person being surveilled, such as prior to boarding a public transportation vehicle, or prior to entering a public or protected facility. Accordingly, different surveillance situations may be benefited by using differently configured surveillance or interrogation stations in which a person is positioned during imaging.

BRIEF SUMMARY OF THE DISCLOSURE

Active imaging systems can include an antenna apparatus configured to transmit toward and receive from a subject in a subject position, millimeter-wave electromagnetic radiation. The antenna apparatus transmits and receives radiation from positions spaced from the subject position and distributed along a locus of points or aperture facing the subject. A controller can include a transceiver configured to operate the antenna apparatus and produce an output representative of the received radiation, and a processor adapted to convert the transceiver output into image data representative of an image of the subject.

Various configurations of an antenna apparatus are possible. A particular configuration can be selected as appropriate for a particular application. For example, the antenna apparatus may include one or a plurality of antenna units, such as a linear or two-dimensional array of antenna units. The antenna unit or units may move along a curved path or be in an array that is curved or straight, and may be fixed or move in a curved or straight path. Antenna units or one or more arrays of antenna units may be fixed in position and pivot to scan a subject from one or more positions distributed about the subject. An assembly, in which an antenna array is adapted to move along a defined path, may move in various ways. For example, the assembly may move along a path extending at least partially around the subject, toward or away from the subject, or in an opposite direction to an associated assembly. Such antenna units may also be oriented at different angular positions along an array. Antenna arrays may also be formed of a plurality of array segments, and a group of arrays may be combined to form an antenna apparatus.

BRIEF DESCRIPTION OF THE DRAWINGS

FIG. 1 is a general diagram showing an active imaging system.

FIG. 2 is a diagram depicting general examples of interrogation stations that may be used in imaging systems.

FIGS. 3–9 are simplified top views of different interrogation stations.

FIGS. 10A–10C are top views of another interrogation station illustrating a sequence of operation.

FIGS. 11A–11D are top views of yet another interrogation station illustrating a sequence of operation.

FIG. 12 is a side view of an interrogation station illustrating an exemplary antenna array configuration.

FIG. 13 is a front view of an optional embodiment of the antenna array of FIG. 12.

FIG. 14 is a top view of an interrogation station illustrating another exemplary antenna array configuration that can be the same interrogation station shown in FIG. 12.

FIG. 15 is a top view of an interrogation station having laterally offset antenna array assemblies.

FIG. 16 is a general diagram depicting an imaging system having an interrogation station with a plurality of antenna apparatus segments.

FIG. 17 is a general diagram depicting one example of an antenna apparatus segment usable in the interrogation station of FIG. 16.

FIG. 18 is a plan view of a plurality of antenna array segments that may be used to form an antenna array.

FIG. 19 is an isometric view of one example of an antenna apparatus segment.

FIG. 20 is a top view of an interrogation station having a plurality of antenna apparatus segments.

DETAILED DESCRIPTION OF THE VARIOUS EMBODIMENTS

Shown generally at **20** in FIG. 1 is an active imaging system. System **20** includes an antenna apparatus **22** and a controller **24**. The system is active in the sense that the antenna apparatus transmits electromagnetic radiation **26** toward a subject **28**, and in response, the subject emits or reflects electromagnetic radiation **30** that is detected by the antenna apparatus. A subject includes all that is presented in an interrogation station of an imaging system for imaging, whether human, animal, or inanimate object. For example, if a person is in an interrogation station for imaging, the subject includes the person as well as any objects supported on the person, such as watches, keys, jewelry, pocket or other knives, coins, clothing accessories, guns, or any other objects that can be imaged. A subject may include one or more persons, animals, objects, or combination of these.

Electromagnetic radiation may be selected from an appropriate frequency range, such as in the range of about 200 megahertz (MHz) to about one terahertz (THz), generally referred to herein as millimeter-wave radiation. Satisfactory imaging may be realized using electromagnetic radiation in the reduced frequency range of one gigahertz (GHz) to about 300 GHz. Radiation in the range of about 5 GHz to about 110 GHz may also be used for producing acceptable images. Such radiation may be either at a fixed frequency or over a range or set of frequencies using several modulation types, e.g. chirp, pseudorandom frequency hop, pulsed, frequency modulated continuous wave (FMCW), or continuous wave (CW).

Many variations of an antenna apparatus are possible. The antenna apparatus may include one or more antenna units, and each antenna unit may include one or more transmitting antennae and one or more receiving antennae. An antenna unit may include a plurality of antennae that may receive radiation in response to transmission by a single antenna. The antennae may be any appropriate type configured to transmit or receive electromagnetic radiation, such as a slot

line, patch, endfire, waveguide, dipole, semiconductor, or laser. Antennae may both transmit and receive. The antennae units may have one or more individual antennae that transmit or receive like polarization or unlike polarized waveforms such as plane, elliptical, or circular polarization, and may have narrow or broad angular radiation beam patterns, depending on the application. Beam width may be relatively broad, i.e. 30–120 degrees for imaging applications that use holographic techniques, while narrow beam widths in the range of 0 to –30 degrees may be used for applications having a narrow field of view requirement. Further, a single antenna may scan a subject by mechanically moving about the subject in a one- or two-dimensional path. A one- or two-dimensional array of antenna units may electronically and mechanically scan a subject. An imaging system may include one or a plurality of antenna apparatus, such as a second antenna apparatus 22'. The antennae apparatus may be protected from the environment by suitable radome material which may be part of the apparatus, or separate, depending on the mechanical motion that is required of the antennae apparatus or array.

An imaging system may include an antenna-apparatus moving mechanism 32, represented by a motor, which moves antenna apparatus 22 relative to a subject 28. Moving mechanism 32 may be mounted relative to a frame 34 for moving the antenna along a path defined by a movement control mechanism, such as a guide 36, including associated motor indexers, encoders or other controls, as appropriate. The moving mechanism may be any appropriate mechanism that moves the antenna apparatus, and may include a stepper motor, servo motor, or other suitable device.

Controller 24 may control operation of motor 32, and coordinate the operation of antenna apparatus 22 with movement of the antenna apparatus. Controller 24 may include hardware, software, firmware, or a combination of these, and may be included in a computer, computer server, or other microprocessor-based system capable of performing a sequence of logic operations. In addition, processing can be distributed with individual portions being implemented in separate system components. In one example, controller 24 may include a transceiver 38, a processor 40, and a memory 42 coupled to the processor for storing data and operating instructions. Such instructions may be embodied as hardware, firmware, or software.

The transceiver, as contemplated herein, includes all structure and functions appropriate for generating, routing, processing, transmitting and receiving millimeter-wave signals between the antenna apparatus and the processor. The transceiver, then in this comprehensive sense, may include multiplexed switching among the antenna units, transmit and receive electronics, and electronic and logic units. The transceiver may be wholly or partly included with a central controller or be wholly or partly resident in an interrogation station 44 housing the antenna apparatus. In certain cases, more than one transceiver is desirable, such as for multiple antenna apparatus or for two dimensional array imaging systems. The transceiver thus sends to and receives from the antenna apparatus scanning signals 46, and outputs received signals 48 to processor 40.

The processor may be any analog or digital computational device, or combination of devices, such as a computer(s), microprocessor(s), or other logic unit(s) adapted to control scanning of a subject and receiving received signals 48 and produce image data 50 representative of an image of at least a portion of the subject. Image data may include any data, whether processed, partially processed or unprocessed, or sub-sets of the data, such as data for a portion of a subject,

data that is manipulated in order to separate, for viewing by an operator or by another processor, objects that may represent a desired class of objects, such as man-made objects, non-physiological or non-living objects, or the like, data identifying or facilitating identification of an object or subject, or measurements or other information relating to a subject that is derived from received signals. The image data may be output to an output device 52, such as a storage device, communication link, such as a network hub, another computer or server, or directly to a display device, such as a video monitor. Memory 42 may be a single device or a combination of devices, and may be local to the processor or remote from it and accessible on a communication link or network.

FIG. 2 illustrates another form of interrogation station 60 for use in some imaging systems, such as system 20 discussed above. Interrogation station 60 includes an antenna apparatus assembly 62 and an antenna path-moving assembly 64. The antenna apparatus assembly may include an antenna apparatus 66, a motor 68, a guide 70, and an intermediate frame 72, similar to interrogation station 44 of imaging system 20. Components 66, 68 and 70 may be mounted relative to intermediate frame 72 for moving the antenna apparatus along an antenna path. Path-moving assembly 64 correspondingly may include a motor 74, a guide 76 and a base frame 78. Motor 74 can act on antenna apparatus assembly 62 to move the position of the antenna path. As is discussed further below, this movement of the antenna apparatus assembly may be used to control access by a person (subject) to the subject position in the interrogation station, or to provide extended scanning of the subject with the antenna apparatus.

Following are various embodiments and configurations of interrogation stations or portions of interrogation stations that may be used in an imaging system, such as in one or more of the imaging systems illustrated in FIGS. 1 and 2. FIG. 3 illustrates a top view of an interrogation station 80 having an antenna apparatus 82 spaced from a subject position 84 having a subject center 86. Antenna apparatus 82 provides for transmitting and receiving electromagnetic radiation along a locus 88 of points, represented by an arc 90. In this example, arc 90 has a center of curvature 92 that is on the opposite side of subject center 86 from the antenna apparatus.

The shape of the locus of points may vary along its length in one or more directions. The locus of points may thus appear to be concave or convex to a subject being imaged, or may have any of various curvilinear configurations, such as an S-shaped curve, or a curve with an incrementally or continuously varying curvature, a configuration with one or more rectilinear segments, or any combination of such configurations. As used herein, the center of curvature of a portion of a locus of points containing three adjacent points is a point equally distant from the three points. The distance from the center of curvature to the three points then corresponds to the radius of an arc passing through the three points.

The antenna apparatus may include at least one antenna unit 94 that moves along a path 96 conforming to arc 90. Various positions of antenna unit 94 along path 96 are illustrated. In an embodiment having only a single antenna unit, the subject position is scanned by mechanically moving the antenna unit along an aperture of interest, such as along arc 90.

Antenna unit 94 also may be part of a vertical antenna array 98 that extends vertically along the height or a portion of the height of a subject 100, such as a person, generally

occupying subject position **84**. In such a case, the vertical array travels along path **96** in an imaging system as illustrated in FIG. **1**. The various positions of antenna unit **94** along the path correspond to positions of antenna array **98** along the path.

Optionally, antenna unit **94** may be part of a horizontal array **102**, with the horizontal array also having additional antenna units, such as antenna units **104**, **106**, **108** and **110**. Horizontal array **102** extends along arc **90**. A subject in the subject position may be scanned both electronically along the array and mechanically by movement of the array vertically.

In some embodiments, a two-dimensional array **112** may be used. Array **112** thus extends vertically and horizontally, and includes antenna units **94**, **104**, **106**, **108**, **110**, and others extending vertically from the antenna units along arc **90**. The subject position may then be electronically scanned from the locus of points covering an area or aperture **114** including arc **90**.

Extended imaging may be provided by one or more of extending arc **90**, providing one or more additional antenna apparatus, rotating a subject **100** about center **86**, as indicated by circle **116**, such as on a platform, and moving arc **90** around the subject position. Arc **90** may be any length considered appropriate for a particular application.

The distance **D1** from the center of the subject position to arc **90** may vary along the arc. An imaging system based on a cylindrical aperture for imaging, as disclosed in U.S. Pat. No. 5,859,609, can be modified in computing image data corresponding to a cylindrical system, by compensating for the difference in distance along the arc. Such a difference can be computed during data processing, or difference values can be stored in memory, such as in a look-up table.

It will be appreciated that by positioning the center of curvature **92** of arc **90** on the opposite side of the subject center **86** from the antenna apparatus **82**, the curve of the arc is more elongate along the length of the arc relative to the subject position. The longer the radius of curvature, the more gradual or straight the arc becomes. Various configurations are accordingly possible. For instance, when the interrogation station is used as a portal for an imaging system at an entrance to a facility, such as an airport, it may be desirable to have people walk along a continuous path. Having the antenna apparatus extending along gentle arcs along the sides of the path reduces the width of the imaging system, allowing it to be used in a smaller space.

If the subject, and therefore the subject position, has a shape that is cylindrical, then a cylindrical arc centered on the subject center would provide a uniform distance between the arc and the subject. This, however, also may not be the case. The shape of arc **90** may generally conform to a side **118** of a subject **100** facing arc **90** and that extends more along one axis, such as a long axis **120**, than along a transverse, short axis **122**, as may be the case with people, particularly with the backs of people. As a result, an arc **90** may be selected that provides a distance **D2** between the locus **88** of points along arc **90** that generally conforms to an expected general shape of at least a portion of a subject.

FIG. **4** illustrates a top view of a further variation of an interrogation station **130** usable in an imaging system, such as imaging system **20**. Interrogation station **130** has an antenna apparatus **132** spaced from a subject position **134** having a subject center **136**. Antenna apparatus **132** may provide for transmitting and receiving electromagnetic radiation along a locus **138** of points, represented by an arc **140**. In this example, arc **140** has a center of curvature **142** that is on the same side of subject center **136** from the

antenna apparatus. Otherwise, interrogation station **130** is similar to interrogation station **80** described above.

The antenna apparatus may include at least one antenna unit **144** that moves along a path **146** conforming to arc **140**. Various positions of antenna unit **144** along path **146** are illustrated. In an embodiment having only a single antenna unit, the subject position is scanned by mechanically moving the antenna unit along an aperture of interest, such as along arc **140**.

Antenna unit **144** also may be part of a vertical antenna array **148** that extends vertically along the height or portion of the height of a subject **150**, such as a person, generally occupying subject position **134**. In such a case, the vertical array travels along path **146** in an imaging system as illustrated in FIG. **1**. The various positions of antenna unit **144** along the path correspond to positions of antenna array **148** along the path.

Optionally, antenna unit **144** may be part of a horizontal array **152**, with the horizontal array also having additional antenna units, such as antenna units **154** and **156**. There also may be additional units between those shown. Horizontal array **152** extends along arc **140**. A subject in the subject position may be scanned both electronically along the array and mechanically by movement of the array vertically.

In some embodiments, a two-dimensional array **158** may be used. Array **158** thus may extend vertically as well as horizontally along arc **140**, and may include antenna units **144**, **154** and **156**, and others extending vertically from the antenna units along arc **140**. The subject position may then be electronically scanned from the locus of points covering an area or aperture **160** including arc **140**.

Extended imaging may be provided by one or more of the following: extending arc **140**; providing one or more additional antenna apparatus; rotating a subject **150** about center **136**, as indicated by circle **162**, such as on a platform; and moving arc **140** around the subject position. Arc **140** may be any length and shape considered appropriate for a particular application.

The distance **D3** from the center of the subject position to arc **140** may vary along the arc. As discussed above, an imaging system based on a cylindrical aperture for imaging, as disclosed in U.S. Pat. No. 5,859,609, can be modified in computing image data corresponding to a cylindrical system, by compensating for the difference in distance along the arc. Such a difference can be computed during data processing, or difference values can be stored in memory, such as in a look-up table.

It will be appreciated that by positioning the center of curvature **142** of arc **140** on the same side of the subject center **136** as the antenna apparatus **132**, the curve of the arc is tighter along the length of the arc relative to the subject position. The shorter the radius of curvature, the sharper the curve of the arc becomes. Various configurations are accordingly possible. For instance, when the interrogation station is used as a portal for an imaging system at an entrance to a facility, such as an airport, it may be desirable to have people walk along a continuous path. Having the antenna apparatus positioned on the sides of the path and shaped to conform generally with the sides of a person positioned on the path may be desirable.

Following this line of thinking, the shape of arc **140** may generally conform to a side **164** of a subject **150** exposed to arc **140** and that extends less along one axis, such as a short axis **166**, than along an orthogonal, long axis **168**, as may be the case with people, particularly with the sides of people. As a result, an arc **140** may be selected that provides a

distance D4 between the locus 138 of points along arc 140 that generally conforms to an expected general shape of a portion of a subject.

FIG. 5 illustrates a top view of an interrogation station 170 having a different design than that of interrogation station 130, but for which an antenna unit 172 of an antenna apparatus 174 moves along an arc 176 having a center of curvature 178 that is on the same side of a subject center 180 of a subject position 182 as the antenna apparatus. Antenna unit 172 may be part of an antenna array 184 that may extend along arc 176 and/or vertically.

The antenna unit may have a beam 186 that may be narrow or broad, depending upon the application. By pivoting the antenna unit about a pivot axis 188 passing through center of curvature 178, the antenna unit moves along arc 176. During such movement, the beam may scan across subject position 182, as represented by double-arrow 190. In some examples, a plurality of such pivoting antenna units, such as antenna units 192 and 194, may be distributed along a further arc, such as arc 196. Arc 196 may be an arc similar to arcs 90 and 140 mentioned above. Optionally, antenna unit 172 may also move along arc 196.

Also, in an optional embodiment, an array 184 may include additional antenna units, such as antenna units 198 and 200 positioned along arc 176. Scanning of the subject position then may be accomplished electronically by activating each of the antenna units along the arc.

FIG. 6 illustrates a top view of an interrogation station 210 that is similar to interrogation station 170, but differs in that a pivot axis 212 for pivoting an antenna unit 214 of an antenna apparatus 216 is positioned opposite from a subject position 218 having a subject center 220. Pivot axis 212 may thus be coincident with a center of curvature 222 of an arc 224 along which the antenna unit moves. By pivoting about pivot axis 212, antenna unit 214 may scan a beam 226 across the subject position 218, as indicated by arrow 228.

Pivoting of the antenna unit may be provided in various ways by a moving mechanism 230. One way is to support the antenna unit on an arm 232 that is adapted to pivot relative to a frame 234. Arm 232 may pivot by reciprocatingly moving an arm end 232a by a drive element 236. Drive element 236 may be driven in a reciprocating fashion by a drive mechanism 238, such as a solenoid or stepper motor. The drive mechanism may be controlled by a controller via a control line 240. A similar moving mechanism also may be used for pivoting antenna units of interrogation station 170.

Optionally, a plurality of antenna units may be positioned along arc 224, such as antenna units 242 and 244, of an antenna array 246. Additionally, the antenna units may move along a larger arc 248, or pivoting antenna units may be distributed along arc 248, such as antenna units 250 and 252 of an antenna array 254.

FIG. 7 illustrates a top view of an interrogation station 260 that may be a further variation of interrogation stations 170 and 210. Interrogation station 260 may include an antenna apparatus 262 that is fixed in position on a frame 264 that may include an enclosure or housing for the antenna apparatus. The antenna apparatus includes an antenna unit 266 that may be part of an antenna array 268. Each antenna unit may have a beam, represented by line 270. A moving mechanism, not shown, may pivot the antenna unit(s) of antenna apparatus 262 about a pivot axis 272 shown aligned with the antenna units. As illustrated in FIGS. 5 and 6, the pivot axis may also be spaced from the antenna units. During pivoting, beam 270 may scan across a subject position 274 having a subject center 276. When the antenna apparatus

includes an array of antenna units, the antenna units may be individually pivoted or may be pivoted collectively.

FIG. 8 illustrates an interrogation station 280 formed of a plurality of antenna apparatus, such as antenna apparatus 282, 284, 286 and 288. These antenna apparatus may each be configured like the antenna apparatus 262 of interrogation station 260, illustrated in FIG. 7. They may be distributed around a subject position 290 having a subject center 292. Antenna apparatus 282, 284, 286 and 288 have respective antenna units, represented by antenna units 294, 296, 298 and 300. The respective antenna units may pivot about respective pivot axes 302, 304, 306 and 308 for scanning respective beams 310, 312, 314 and 316 across the subject position. The various antenna apparatus may be fixedly mounted to a frame 318. As illustrated in FIGS. 5 and 6, the pivot axis may also be spaced from the antenna unit.

More or fewer antenna apparatus may be used. The antenna apparatus are positioned to provide a desired coverage of the surface of a subject positioned in the subject position. In the configuration shown, the antenna apparatus are positioned to allow a subject to enter the interrogation station along a path 320 at an entrance 322, stand at the subject position during imaging, and leave through an exit 324 opposite from the entrance.

FIG. 9 illustrates an interrogation station 330 having first and second antenna apparatus 332 and 334 positioned on opposite sides of a subject position 336 having a subject center 338. In the embodiment shown, each antenna apparatus has an antenna unit 340 that may be part of an antenna array 342 that transmits and receives electromagnetic radiation along an arc 344.

Antenna apparatus 332 and 334 may be formed as combinations of antenna apparatus 82 and 132 described previously. Each arc 344 may have an intermediate portion 344a, with a respective center of curvature 346 and 348 positioned between the associated arc portion and the subject center. Each arc 344 also may have end portions 344b and 344c that have respective centers of curvature 350 and 352 positioned on the opposite side of the subject center from the associated arc portion. Optionally, terminal ends 344d and 344e may be formed in a straight line so that an antenna unit on that portion of the arc more directly faces a subject in the subject position.

Antenna units may be distributed along the respective arcs, may move along the arc, or both. Optionally, the arcs of the antenna apparatus, such as arcs 353 and 354, may include other arc portions. These arcs thus may include intermediate portions having respective centers 350 and 352, and end portions having respective centers 346 and 348.

In the example shown, first antenna apparatus 332 is fixed in position relative to the subject position, and second antenna apparatus 334 is adapted to move relative to the subject position. Second antenna apparatus 334 may be mounted relative to an apparatus frame 355 with a moving mechanism that is adapted to move antenna apparatus 334 relative to a base frame 356. The second antenna apparatus may thus be shifted between a first position 358, close to or proximal the subject position for imaging, and a distal, second position 360 spaced further away from the subject position. The antenna apparatus, thus, moves in a direction 362 that is transverse to associated arc 344.

Interrogation station 330 may be useful for providing a close-fitting enclosure, defined by opposing arcs 344, around a subject during imaging that has reduced-width passageways 364 and 366. A subject may then move into and out of the interrogation station through the passageways when the distance between the antenna arrays is increased. As an

optional design, both of the antenna arrays can move toward and away from the subject position, and thereby toward and away from each other. In this case, first antenna apparatus 332 may be mounted relative to an apparatus frame 355' with associated moving mechanism that is adapted to move antenna apparatus 332 relative to a base frame 356'. If more antenna arrays surround the subject position, any combination of them can be made to move toward and away from the subject position.

FIGS. 10 and 11 illustrate top views interrogation stations that include barriers around arcs associated with antennae apparatus in which the barriers move in the direction of the arcs. These arcs may be concentric or eccentric relative to the center of the subject position.

FIGS. 10A–10C depict an interrogation station 370 having first and second antenna apparatus assemblies 372 and 374, each having a respective antenna apparatus 376 and 378. Each antenna apparatus correspondingly includes one or more antenna units 380 and, if appropriate, an antenna array 382, such as has been described with reference to the previous figures. In particular, apparatus assemblies 372 and 374 include respective barriers 384 and 386 associated respectively with antenna apparatus 372 and 374. These barriers may cover or enclose associated arcs 387 and 388, along which electromagnetic radiation is transmitted and received, as has been described. The barriers may conform to the arcs, as shown, although other shapes may also be used. Apparatus assemblies 372 and 374 may be moved along an apparatus path, such as defined by a track 389.

As viewed in the figures, a subject 390 may enter interrogation station 370 along a subject path 392 through an entrance 394. Initially, barriers 384 and 386 may be abutting in a position downstream relative to a subject position 396 along path 392 and blocking an exit 398 from the interrogation station. This barrier supports the objective of having the subject stop on the subject position and remain there during imaging.

Initially, the antenna apparatus 376 and 378 may perform imaging along arcs 387 and 388 with the barriers in a starting or blocking position as shown in FIG. 10A. The barriers shown each span an arc of about 90 degrees, so the two antenna apparatus are able to scan half of a cylindrical aperture surrounding the subject position. Other lengths and shapes of arcs and other numbers of antenna apparatus assemblies may be used.

After scanning the first side of the subject, the antenna apparatus assemblies may move in opposite directions along track 389 to an upstream position on path 392 at the entrance 394 to the interrogation station. The other side of the subject is then scanned, and with the exit open, the subject may be allowed to leave the interrogation station, as shown in FIG. 10B. The antenna apparatus assemblies are then again moved along track 389 in opposite directions to the initial position blocking path 392 at exit 398, and opening entrance 394, permitting a second subject 390' to enter the interrogation station.

An interrogation station 400, illustrated in FIGS. 11A–11D, provides for continuous rotation of an antenna apparatus assembly 402. Assembly 402 is shown as having an antenna apparatus 404 extending along an arc 406 of about 120 degrees, although other arc lengths longer or shorter than arc 406 may be used. Antenna apparatus assembly 402 includes an antenna unit 408, which may be included in an antenna array 410. A barrier 412 may extend along the arc. The antenna apparatus assembly may be adapted to move along a path defined by a guide, as

represented by a track 414. Track 414 extends at least partially around a subject position 416.

Initially, a subject 418 may enter the interrogation station through an entrance 420 and along a path 422, stopping at the subject position. The antenna apparatus 404 then performs imaging from positions along arc 406 with the barrier in a starting or blocking position shown in FIG. 11A. The barrier may block an exit 424 from the interrogation station, downstream along path 422 from the subject position. After scanning a first side of the subject, the antenna apparatus assembly moves along track 414 to a second position, which may be complementary to the initial position, as shown in FIG. 11B. The next 120 degrees of image of the subject may then be scanned.

Assembly 402 then may move to a third position at which the final 120 degrees of scanning of the subject is performed, as shown in FIG. 11C. The exit from the interrogation station is open when assembly 402 in this third position, allowing the subject to leave the interrogation station. The antenna apparatus assembly 402 may then move along track 414 to the initial position, blocking path 422 at exit 424. With the assembly in this position, entrance 420 is again unobstructed, permitting a second subject 418' to enter the interrogation station.

FIG. 12 illustrates a feature of an interrogation station 430 that may be used in various of the interrogation stations illustrated in the other figures. FIG. 12 illustrates simplistically an antenna apparatus 432 including a vertical array 434 of antenna units, including antenna units 436, 437, 438 and 439, represented by cone shapes for simplicity. Array 434 is mounted along a vertical frame 442. The array is generally directed toward a subject position 444 extending generally parallel to the array.

In a lower portion 434a of the array, the antenna units, including antenna unit 439, are mounted relative to the array to extend generally perpendicular to a line 446 corresponding to frame 442. In an upper portion 434b of the array, the antenna units are mounted at an acute angle to the line of the array. For instance, antenna unit 436 is shown to be mounted at an angle A1 of about 30 degrees from the perpendicular to the line of the array, or about 60 degrees relative to the line of the array. Any suitable angle may be used in a particular application, as is appropriate to obtain the desired coverage of the subject. Antenna units 437, 438 and others are at progressively increased angles relative to the line of the array until they align with the perpendicular to the array, as in lower array portion 434a. In this example, upper array portion 434b generally extends above the level of the subject position. The subject position can correspond to the expected general position of a subject located in the subject position. Accordingly, all of the antenna units are directed toward the subject position. The antenna units in upper array portion 434b then are able to provide an imaging perspective from above the subject position.

FIG. 13 illustrates a simplified front view of a variation of antenna apparatus 432 illustrated in FIG. 12. In this example, the antenna units in the lower portion 434a of array 434 are directed in different circumferential orientations or directions about the line 446 of the array. For example, antenna unit 439 is directed forward. Antenna units 447 and 448, respectively above and below antenna unit 439, may be directed left and right, respectively, as viewed in the figure. This pattern may be repeated along the array. In upper array portion 434b, the antenna units are variously directed left, forward, and right as in the lower array portion. Additionally, the antenna units may be directed downwardly at an acute angle, as was described with reference to FIG. 12. For

example, antenna unit **436** may point downwardly and forward, antenna unit may point downwardly and to the right (from the perspective of a viewer of the figure), and antenna unit **438** may point downwardly and to the left. In this example, the amount that the antenna units are directed downwardly at an acute angle to the line of the array decreases with increasing distance down the array. Many other variations in antenna unit orientation may be used, as appropriate to provide imaging characteristics desired for a given application.

Although this discussion has been directed to a vertical antenna array, it also applies to horizontal antenna array. For example, FIG. **14** illustrates a simplified top view of another interrogation station **450** having an antenna apparatus **452** positioned adjacent to a subject position **454**. In this example, the antenna apparatus extends along a line in the form of an arc **456**. An antenna array **458** includes a plurality of antenna units, including antenna units **460**, **461**, **462**, **463** and **464**, are distributed along the arc. Arc **456** has a center of curvature **466** spaced from a center **468** of the subject position, as shown. Other shapes and curvatures of the arc may be used. For instance, the array could extend along a rectilinear line **470** and have antennae positioned at different angles versus position as shown in FIG. **12**, but in a horizontal position.

Array **458** may include an intermediate portion **458a** along which the antenna units, such as antenna unit **462**, extend normal to the line of the array, which in this example is arc **456**. The array also includes end portions **458b** and **458c**. The antenna units, such as antenna units **460**, **461**, **463** and **464**, in these end portions are mounted at an acute angle relative to the arc. For example, antenna unit **461** is mounted at an angle **A2** of about 10 degrees, corresponding to a complementary angle of about 80 degrees relative to the arc. The antenna units, then, in these end portions may be oriented more directly toward subject position **454** than would be the case if they were mounted orthogonally to the arc of the array.

Antenna array **458** may extend only horizontally along arc **456**, in which case the side of a subject in a subject position facing the array may be fully scanned by mechanically moving the arc vertically. Optionally, an array **458** may be part of a two-dimensional array **472** of an interrogation station **474**, which array also includes array **434** depicted in FIG. **12**. For instance, the view of the array in FIG. **14** may be the view taken along line **13—13** in FIG. **12**. If array **472** is large enough it may be possible to obtain an image of the side of a subject facing the array by electronically scanning the subject. In some examples, an image of only a portion of a subject may be desired; in which case, the array may correspond to only a portion of the subject.

A top view of yet another form of interrogation station is illustrated in FIG. **15**. An interrogation station **480** includes first and second antenna apparatus **482** and **484** positioned or adapted to be positioned relative to a subject position **486**. Antenna apparatus **482** may include an antenna unit or array of antenna units adapted to transmit and receive electromagnetic radiation along an arc **488**. Arc **488** in this example is semi-circular, extending from a first end **488a** to a second end **488b** around a center of curvature **490**. Similarly, antenna apparatus **484** extends in a semi-circular arc **492** having first and second ends **492a** and **492b**, about a center of curvature **494**. Barriers may be associated with these arcs, as has been described, and the arcs may correspond to movement or location of one or more antenna units during imaging of a subject. It is seen that center of curvature **490** is at the end **492a** of arc **492**. Similarly, center of curvature

494 is at the end **488a** of arc **488**. In this particular construction, then, the four arc ends, the two centers of curvature and the subject position are aligned along a common straight line **496**.

In this configuration, first ends **488a** and **492a** of the arcs are positioned closer to the subject position than the other ends. The two arcs may be considered to be offset relative to each other, in that the arcs form an asymmetrical configuration about line **496**. The arcs, thereby, form a partial definition of a subject path **498** having an entrance **500** and an exit **502**. The subject position is located where the antenna arcs are located the closest to the subject path. Further, when the subject is in the subject position, the arcs surround the subject, allowing for imaging of all sides of the subject without moving an antenna apparatus or moving the subject. Further, the arcs define the boundaries of the path between the entrance and exit. Other configurations may also be used.

Imaging systems may be used in a wide variety of applications. They may be used in conventional fixed locations where security checks are currently made, such as in restricted facilities, or at entrances to public facilities that may be considered likely to be of interest to persons having destructive or adverse inclinations. In such installations, it is important to keep the imaging systems functional in order to interrogate a potentially continuous flow of personnel through the associated interrogation station or stations.

Imaging systems are also useful for the temporary interrogation of subjects in ad hoc applications that do not warrant a fixed or permanent installation. Examples include special or infrequent events, such as sports or political activities. Another example is a military operation in which troops are moving across a large territory, and check-points are set up at points of access for non-military personnel. For these applications, it may be desirable to have an imaging system that can be readily assembled for use, and then disassembled for reuse at another location.

FIGS. **15—19** illustrate various aspects of imaging systems that can facilitate assembly, disassembly, upgrading the imaging system, and maintenance. FIG. **16** is a block diagram of an imaging system **510** having an antenna apparatus **512** and a controller **514**. The function and structure of imaging system **510** corresponds to imaging systems described above, and have the particular features described now.

Antenna apparatus **512** can include a plurality of segments or modules, such as array modules **516**, **517** and **518**. These modules in combination can form the antenna apparatus. A frame or mounting assembly **520** can join the various modules together in a given configuration, such as in an arc **522** of an array **524**.

Optionally, the modules **516**, **517** and **518** can form one of a plurality of interrogation segments, such as interrogation segment **526**. Additional interrogation segments, such as interrogation segment **528**, may be formed of associated modules, such as array modules **530**, **531** and **532**. Modules **530**, **531** and **532** may be joined by a frame or mounting assembly **534**. In turn, interrogation segments **526** and **528**, and others, may be joined by a base mounting assembly **538**, to form antenna apparatus **512**.

A communication link, such as link **540**, connects each module to a module input/output device **542** of controller **514**.

FIG. **17** is a general schematic of one configuration of a first array module, such as module **516**, connected to a second array module, such as module **517** of an antenna apparatus, such as antenna apparatus **512**. Module **516** may

include a frame **544** that is attached to a corresponding frame **546** of module **517**. Frames **544** and **546** can be attached together in various configurations, such as by connection to a common frame or mounting assembly, or by joining them as segment frames, as shown, with an attachment assembly **552**, such as brackets **554** and **556**. Other structures may be used to attach the array modules together.

Each array module can have a plurality of antenna units, such as antenna units **558**, **559** and **560**. When the plurality of array modules is mounted together, the respective antenna units may form collectively an antenna array **562**. Each antenna unit is in communication with a transceiver **564**, which transceiver may be resident as part of the array module; mounted on a common base mounting assembly; or at a location remote from the antenna apparatus. The transceiver may then be in communication with a processor or other signal controller device, such as via an input/output device **566**.

FIG. **18** depicts a plurality of array modules, such as modules **516**, **517** and **518**, positioned along an arc **568** and directed toward a subject position **570** to form an antenna apparatus **571**. In this example, each array module has a plurality of antenna units **572** disposed along a rectilinear line, such as lines **574** and **576** associated with modules **516** and **517**. The array modules may be mounted at respective angles, such as angle **A3**, relative to each other. The result is that arc **568** is comprised of a plurality of chords. The same array modules can accordingly be configured to form any appropriate arc, including a rectilinear line for which the radius of curvature may be considered to be at an infinite distance.

An example of an interrogation station **580** using a plurality of array modules **516**, **517** and **518** to form an antenna apparatus **571** is shown in FIG. **19**. The array modules form an array **582** extending horizontally around a subject position **584**. The array may be moved up and down to scan mechanically a subject in the subject position by a moving mechanism **586**. A frame **588** forms a barrier that also supports the antenna apparatus. A transceiver **590** may control operation of the antenna array and antenna units during scanning of a subject.

Optionally, interrogation station **580** may be configured as an interrogation segment **592** that forms part of an interrogation station **594** shown in FIG. **20**. As illustrated, interrogation station **594** may include a plurality of interrogation segments, such as segments **592**, **595** and **596**. The interrogation segments may be mounted collectively on a segment frame **598** to form a combined antenna array **600** formed by the arrays of each of the interrogation segments and extending along a combined arc **602**. The transceivers **590** of the interrogation segments may be in communication with a shared controller **604**. Optionally, the interrogation segments may share a single transceiver mounted separately, or a transceiver included in controller **604**, as was described with reference to controller **24** of imaging system **20**.

It will be appreciated that the foregoing imaging systems, interrogation stations and antenna apparatus have varying characteristics and features. Various of these features may be used in various combinations. For example, the antenna arrays described with reference to any of the interrogation stations may be constructed with array segments each having a plurality of arrays, transceivers, and/or may be constructed as interrogation segments. These array segments and interrogation segments facilitate maintenance, since faulty parts can be readily replaced, or the entire system may be readily assembled or disassembled, as appropriate. Further, an interrogation station may have antenna units

mounted at differing angles along an arc or with different polarizations and beam angular width, either vertically or horizontally for the entire antennae apparatus, transmitting or receiving arrays, or individual antenna units within an arrayarray arc may be formed of antenna units formed in groups or segments extending along a line that varies from the arc, but collectively form the arc. Array segments may be oriented along the line of an array that varies from the perpendicular line of the array. Various combinations and configurations are therefore possible.

Some embodiments of imaging systems having any of the various described interrogation stations may use a transmitting signal that incorporates frequencies in the range of 24 to 30 GHz, FMCW modulation, and having signal content that meets FCC unlicensed operation requirements and is outside of any restricted US Government frequency bands. Pulse lengths may range from 2–10 microseconds. Antennae beam widths may range from 20–120 degrees for broad beam implementation, or from 1 to 30 degrees for narrow beam width applications, depending on the image formation signal processor requirements. Various system polarizations may be used. Examples include same polarization, cross polarization, elliptical polarization, right circular polarization, and/or left circular polarization.

Accordingly, while the inventions defined in the following claims have been particularly shown and described with reference to the foregoing preferred embodiments, those skilled in the art will understand that many variations may be made therein without departing from the spirit and scope of the inventions. Other combinations and sub-combinations of features, functions, elements and/or properties may be claimed through amendment of the present claims or presentation of new claims in this or a related application. Such amended or new claims, whether they are directed to different combinations or directed to the same combinations, whether different, broader, narrower or equal in scope to the original claims, are also regarded as included within the subject matter of the present disclosure. The foregoing embodiments are illustrative, and no single feature or element is essential to all possible combinations that may be claimed in this or later applications. Where the claims recite “a” or “a first” element or the equivalent thereof, such claims should be understood to include one or more such elements, neither requiring nor excluding two or more such elements. Further, cardinal indicators, such as first, second or third, for identified elements are used to distinguish between the elements, and do not indicate a required or limited number of such elements, nor does it generally indicate a particular position or order of such elements.

INDUSTRIAL APPLICABILITY

The described imaging systems and components of imaging systems, as well as the methods relating thereto, are applicable to surveillance, metric, and other industries in which subject images are utilized.

What is claimed is:

1. An imaging system comprising:

an antenna apparatus configured to transmit toward and receive from a subject in a subject position having a center, electromagnetic radiation in a frequency range of about 200 MHz to about 1 THz, from positions spaced from the subject position and distributed along a first locus of points including at least a first curved locus of points having a center of curvature spaced from the center of the subject position;

15

a transceiver configured to operate the antenna apparatus and produce an output representative of the received radiation; and

a processor adapted to convert the transceiver output into image data representative of an image of at least a portion of the subject.

2. A system according to claim 1, in which the center of the subject position is between the center of curvature of the curved locus of points and the associated locus of points.

3. A system according to claim 2, in which the antenna apparatus is adapted to move in a curved path along the curved locus of points.

4. A system according to claim 3, in which the antenna apparatus extends along the curved locus of points.

5. A system according to claim 4 for use on a subject having an eccentric shape relative to the center of the subject position, and in which the locus of points has a curve corresponding to the shape of the subject facing the curved locus of points.

6. A system according to claim 3 for use on a subject having an eccentric shape relative to the center of the subject position, and in which the locus of points has a curve corresponding to the shape of the subject facing the curved locus of points.

7. A system according to claim 3, in which the path along the curved locus of points has a plurality of different centers of curvature.

8. A system according to claim 2, in which the antenna apparatus extends along the curved locus of points.

9. A system according to claim 8 for use on a subject having an eccentric shape relative to the center of the subject position, and in which the locus of points has a curve corresponding to the shape of the subject adjacent to the curved locus of points.

10. A system according to claim 8, in which the path along the curved locus of points has a plurality of different centers of curvature.

11. A system according to claim 2, in which the curved locus of points defines a first arc having opposite ends, and the subject position is closer to one end of the arc than the other end.

12. A system according to claim 11, in which the subject position is generally between the center of curvature of the curved locus of points and the one end of the arc.

13. A system according to claim 11, in which the antenna apparatus is further configured to transmit and receive electromagnetic radiation distributed along a second locus of points spaced from the first locus of points, the second locus of points including a second curved locus of points forming a second arc having a center of curvature and opposite ends, and the subject position is closer to one end of the second arc than the other end of the second arc.

14. A system according to claim 13, in which the subject position is between the first and second arcs.

15. A system according to claim 14, in which a line connecting the one end of the first arc with the one end of the second arc passes through the object position.

16. A system according to claim 13, in which the first and second arcs form a generally S-shaped subject passageway.

17. A system according to claim 1, in which the center of curvature of the curved locus of points and the antenna apparatus are on the same side of the center of the subject position.

18. A system according to claim 17, in which the center of curvature of the curved locus of points is between the center of the subject position and the antenna apparatus.

16

19. A system according to claim 18, in which the antenna apparatus is adapted to move in a curved path along the curved locus of points.

20. A system according to claim 19, in which the antenna apparatus is curved along the curved locus of points.

21. A system according to claim 20 for use on a subject having an eccentric shape relative to the center of the subject position, and in which the locus of points has a curve corresponding to the shape of the subject facing the curved locus of points.

22. A system according to claim 19, in which the antenna apparatus includes first antenna array moving in a first arc defining a first curved locus of points and a second antenna array moving in a second arc defining a second curved locus of points, the first and second arcs having respective centers of curvature positioned between the center of the subject position and the respective antenna array.

23. A system according to claim 22, further comprising an array-apparatus moving mechanism adapted to move the first antenna array between a distal position and a proximal position, the array being closer to the subject position when in the proximal position than when in the distal position.

24. A system according to claim 19 for use on a subject having an eccentric shape relative to the center of the subject position, and in which the locus of points has a curve corresponding to the shape of the subject facing the curved locus of points.

25. A system according to claim 18, in which the antenna apparatus extends along the curved locus of points.

26. A system according to claim 25, in which the antenna apparatus includes a first antenna array moving in a first arc defining a first curved locus of points and a second antenna array moving in a second arc defining a second curved locus of points, the first and second arcs having respective centers of curvature positioned between the center of the subject position and the respective antenna array.

27. A system according to claim 26, further comprising an array-apparatus moving mechanism adapted to move the first antenna array between a distal position and a proximal position, the array being closer to the subject position when in the proximal position than when in the distal position.

28. A system according to claim 25 for use on a subject having an eccentric shape relative to the center of the subject position, and in which the locus of points has a curve corresponding to the shape of the subject facing the curved locus of points.

29. A system according to claim 25, in which the antenna apparatus includes at least one antenna unit, and each antenna unit pivots about a pivot axis spaced from the center of curvature of the curved locus of points, whereby each antenna unit scans across at least a portion of the subject position as the antenna unit pivots about the pivot axis.

30. A system according to claim 18, in which the antenna apparatus includes at least one antenna unit, and each antenna unit pivots about a pivot axis spaced from the center of curvature of the curved locus of points, whereby each antenna unit scans across at least a portion of the subject position as the antenna unit pivots about the pivot axis.

31. A system according to claim 30, in which each antenna unit pivots about a fixed pivot axis.

32. A system according to claim 18, in which the locus of points has a plurality of centers of curvature.

33. A system according to claim 17, in which the antenna apparatus is between the center of the subject position and the center of curvature of the curved locus of points.

34. A system according to claim 33, in which the antenna apparatus includes at least one antenna unit, and each

17

antenna unit pivots about a pivot axis spaced from the center of curvature of the curved locus of points, whereby each antenna unit scans across at least a portion of the subject position as the antenna unit pivots about the pivot axis.

35. A system according to claim 34, in which each antenna unit pivots about a fixed pivot axis.

36. A system according to claim 33, in which the locus of points has a plurality of different centers of curvature.

37. A system according to claim 33, in which the curved locus of points is convex when viewed from the subject position.

38. A system according to claim 17, in which the antenna apparatus includes at least one antenna unit, and each antenna unit pivots about a pivot axis substantially on the center of curvature of the curved locus of points, whereby each antenna unit scans across at least a portion of the subject position as the antenna unit pivots about the pivot axis.

39. A system according to claim 38, in which each antenna unit pivots about a fixed pivot axis.

40. A system according to claim 17, in which the antenna apparatus includes at least one antenna unit, and each antenna unit pivots about a pivot axis substantially passing through the antenna unit, whereby each antenna unit scans across at least a portion of the subject position as the antenna unit pivots about the pivot axis.

41. A system according to claim 40, in which each antenna unit pivots about a fixed pivot axis.

42. A system according to claim 1, in which the locus of points has a plurality of different centers of curvature.

43. A system according to claim 42, in which the locus of points has an intermediate curved portion and an end curved portion on each end of the intermediate curved portion, with the intermediate curved portion having a longer radius of curvature than the radius of curvature of the end portions.

44. A system according to claim 43 for use on a subject having an eccentric shape relative to the center of the subject position, and in which the locus of points has a curve corresponding to the shape of the subject facing the curved locus of points.

45. A system according to claim 42, in which the locus of points has an intermediate curved portion and an end portion on each end of the intermediate curved portion that is angled toward the center of the subject position relative to the intermediate curved portion.

46. A system according to claim 45, in which the end portions are rectilinear.

47. A system according to claim 45, in which the end portions are curved, with the intermediate curved portion having a shorter radius of curvature than the radius of curvature of the end portions.

48. A system according to claim 45 for use on a subject having an eccentric shape relative to the center of the subject position, and in which the intermediate portion and end portions have a combined shape corresponding to the shape of the subject facing the intermediate and end portions.

49. An imaging system comprising:

an antenna apparatus configured to transmit toward and receive from a subject in a subject position having a center, electromagnetic radiation in a frequency range of about 200 MHz to about 1 THz, from positions spaced from the subject position and distributed along a first locus of points including at least a first curved locus of points having a center of curvature and defining a first arc having opposite ends, with the subject position being closer to one end of the arc than the other end;

18

a transceiver configured to operate the antenna apparatus and produce an output representative of the received radiation; and

a processor adapted to convert the transceiver output into image data representative of an image of at least a portion of the subject.

50. A system according to claim 49, in which the subject position is generally between the center of curvature of the curved locus of points and the one end of the arc.

51. A system according to claim 50, in which the antenna apparatus is further configured to transmit and receive electromagnetic radiation distributed along a second locus of points spaced from the first locus of points, the second locus of points including a second curved locus of points forming a second arc having a center of curvature and opposite ends, and the subject position is closer to one end of the second arc than the other end of the second arc.

52. A system according to claim 51, in which the subject position is between the first and second arcs.

53. A system according to claim 52, in which a line connecting the one end of the first arc with the one end of the second arc passes through the object position.

54. A system according to claim 53, in which the line also passes through the other end of the first arc and the other end of the second arc.

55. A system according to claim 53, in which the one end of each of the first and second arcs is adjacent to the center of the other of the first and second arcs.

56. An imaging system comprising:

an array of antenna units configured to transmit toward and receive from a subject in a subject position, electromagnetic radiation in a frequency range of about 200 MHz to about 1 THz, from positions spaced from the subject position and distributed in the array along at least a line, each antenna unit being oriented at a fixed angle to the line of the array, at least one antenna unit being oriented at an acute angle to the line of the array; a transceiver configured to operate the antenna apparatus and produce an output representative of the received radiation; and

a processor adapted to convert the transceiver output into image data representative of an image of at least a portion of the subject.

57. A system according to claim 56, in which the line of the array is rectilinear.

58. A system according to claim 56, in which the line of the array is at least partially curved.

59. A system according to claim 58, in which the line of the array includes an arc having a center of curvature spaced from the subject position, and a plurality of antenna units disposed along the arc are oriented at an acute angle relative to the arc.

60. A system according to claim 59, in which the antenna units disposed along the arc are oriented generally toward the subject position.

61. A system according to claim 56, in which the angles of antenna units vary along a length of the array.

62. A system according to claim 56, in which at least a portion of the antenna units are oriented generally toward the subject position.

63. A system according to claim 56, in which the array is two-dimensional.

64. A system according to claim 63, in which the array is planar.

65. A system according to claim 63, in which the array extends in at least one direction along a curved line.

66. A system according to claim 65, in which the angles of antenna units vary along a length of the array.

67. An imaging system comprising:

- an array of antenna units configured to transmit toward and receive from a subject in a subject position, electromagnetic radiation in a frequency range of about 200 MHz to about 1 THz, from positions spaced from the subject position and distributed in the array along at least a line, each antenna unit having a given orientation on the line of the array, at least two antenna units having different orientations on the line of the array;
- a transceiver configured to operate the antenna apparatus and produce an output representative of the received radiation; and
- a processor adapted to convert the transceiver output into image data representative of an image of at least a portion of the subject.

68. A system according to claim 67, in which at least two antenna units have different circumferential orientations on the line of the array.

69. A system according to claim 68, in which the at least one of the at least two antenna units is also oriented at an acute angle to the line of the array.

70. A system according to claim 67, in which the at least one of the at least two antenna units is also oriented at an acute angle to the line of the array.

71. An imaging system comprising:

- a first antenna apparatus configured to transmit toward and receive from a subject in a subject position, electromagnetic radiation in a frequency range of about 200 MHz to about 1 THz, from positions spaced from the subject position and distributed along a first locus of points;
- a first moving mechanism adapted to move the antenna apparatus along a first antenna path;
- a second moving mechanism adapted to move the first moving mechanism and the antenna apparatus in a manner moving the antenna path in a direction transverse to the antenna path, between a first path position and a second path position; and
- a controller configured to operate the antenna apparatus when the antenna path is in the second path position, and to produce image data representative of an image of at least a portion of the subject.

72. A system according to claim 71, further comprising a second antenna apparatus configured to transmit toward and receive from a subject in the subject position having a center, electromagnetic radiation in a frequency range of about 200 MHz to about 1 THz, from positions spaced from the subject position and distributed along a second locus of points spaced from the first locus of points, the second moving mechanism moving the first moving mechanism and the first antenna apparatus relative to the second antenna apparatus, and the controller configured to operate the second antenna apparatus.

73. A system according to claim 72, further comprising a third moving mechanism adapted to move the second antenna apparatus along a second antenna path.

74. A system according to claim 73, in which the first and second antenna paths are on opposite sides of the subject position.

75. An imaging system comprising:

- an antenna apparatus configured to transmit toward and receive from a subject in a subject position, electromagnetic radiation in a frequency range of about 200

MHz to about 1 THz, from positions spaced from the subject position and distributed along a first locus of points;

- a first moving mechanism adapted to move the antenna apparatus along a first antenna path;
- a second moving mechanism adapted to move the first moving mechanism and the antenna apparatus in a manner moving the antenna path in a continuous loop around the subject position; and
- a controller configured to operate the antenna apparatus, when the antenna path is in different positions around the loop, and first and second moving mechanisms, and to produce image data representative of an image of at least a portion of the subject.

76. A system according to claim 75, in which the subject is a person, the system including a continuous subject path passing through the subject position and a barrier extending along the first antenna path, and in which the second moving mechanism is adapted to move the barrier with the antenna apparatus and the first moving mechanism, the controller further being configured to operate the second moving mechanism to position the barrier on the subject path downstream from the subject position prior to initiating operation of the antenna apparatus, and to position the barrier away from the subject path downstream from the subject position after initiating operation of the antenna apparatus.

77. An imaging system comprising:

- first and second antenna apparatus configured to transmit toward and receive from a subject in a subject position, electromagnetic radiation in a frequency range of about 200 MHz to about 1 THz, from respective positions spaced from the subject position;
- a first moving mechanism adapted to move the first antenna apparatus along a first antenna path;
- a second moving mechanism adapted to move the second antenna apparatus along a second antenna path spaced from the first antenna path;
- a third moving mechanism adapted to move the first moving mechanism and the first antenna apparatus in a first direction around the subject position, and adapted to move the second moving mechanism and the second antenna apparatus in a second direction opposite the first direction around the subject position; and
- a controller configured to operate the antenna apparatus, when the antenna path is in different positions around the loop, and first and second moving mechanisms, and to produce image data representative of an image of at least a portion of the subject.

78. A system according to claim 77, in which the controller is configured to operate the third moving mechanism to move the first and second antenna apparatus between a first antenna position in which the first and second antenna apparatus are adjacent each other and a second antenna position spaced from the first antenna position.

79. A system according to claim 78, in which the first and second antenna apparatus are also adjacent each other in the second antenna position.

80. A system according to claim 79, in which the subject is a person, the system including a continuous subject path passing through the subject position, a first barrier extending along the first antenna path, and a second barrier extending along the second antenna path, the first and second barriers being adjacent to each other on the subject path downstream from the subject position in the first antenna position, and being adjacent to each other on the subject path upstream from the subject position in the second antenna position.

81. An imaging system comprising:

an antenna apparatus configured to transmit toward and receive from a subject in a subject position having a center, electromagnetic radiation in a frequency range of about 200 MHz to about 1 THz, from positions spaced from the subject position and distributed along a first arc having opposite ends, and the subject position is closer to one end of the arc than the other end;

a transceiver configured to operate the antenna apparatus and produce an output representative of the received radiation; and

a processor adapted to convert the transceiver output into image data representative of an image of at least a portion of the subject.

82. A system according to claim **81**, in which the arc has a center of curvature, and the subject position is generally between the center of curvature of the arc and the one end of the arc.

83. A system according to claim **81**, in which the antenna apparatus is further configured to transmit and receive electromagnetic radiation distributed along a second arc spaced from the first arc, the second arc having a center of curvature and opposite ends, and the subject position is also closer to one end of the second arc than the other end of the second arc.

84. A system according to claim **83**, in which the subject position is between the first and second arcs.

85. A system according to claim **84**, in which a line connecting the one end of the first arc with the one end of the second arc passes through the object position.

86. A method of imaging comprising:

transmitting toward a subject in a subject position having a center, electromagnetic radiation in a frequency range of about 200 MHz to about 1 THz, from positions spaced from the subject position and distributed along a first locus of points including at least a first curved locus of points having a center of curvature spaced from the center of the subject position;

receiving from the subject reflected electromagnetic radiation;

producing an output representative of the received radiation; and

converting the output into image data representative of an image of at least a portion of the subject.

87. A method according to claim **86**, in which transmitting radiation includes transmitting radiation from an antenna apparatus, and receiving radiation includes receiving information on an antenna apparatus, the method further comprising moving the antenna apparatus in a curved path along the curved locus of points.

88. A method according to claim **87**, in which moving the antenna apparatus includes moving the antenna apparatus along a curved locus of points having a center of curvature on the opposite side of the center of the subject position from the antenna apparatus.

89. A method according to claim **87**, in which moving the antenna apparatus includes moving the antenna apparatus along a curved locus of points corresponding to a shape of a subject that is eccentric relative to the center of the subject position.

90. A method according to claim **87**, in which moving the antenna apparatus includes moving the antenna apparatus along a curved locus of points having a plurality of centers of curvature.

91. A method according to claim **90**, in which moving the antenna apparatus includes moving the antenna apparatus along a curved locus of points having a plurality of different centers of curvature.

92. A method according to claim **86**, in which the curved locus of points defines a first arc having opposite ends, the method further comprising positioning the subject position closer to one end of the arc than the other end.

93. A method according to claim **92**, in which transmitting radiation includes transmitting radiation from positions distributed along a second locus of points spaced from the first locus of points, the second locus of points including a second curved locus of points forming a second arc having a center of curvature and opposite ends, and positioning the subject position includes positioning the subject position closer to one end of the second arc than the other end of the second arc.

94. A method according to claim **87**, in which moving the antenna apparatus includes moving the antenna apparatus along a curved locus of points having a center of curvature on the same side of the center of the subject position as the antenna apparatus.

95. A method according to claim **94**, in which moving the antenna apparatus includes moving the antenna apparatus along a curved locus of points having a center of curvature between the center of the subject position and the antenna apparatus.

96. A method according to claim **95**, in which the antenna apparatus includes a first antenna array and a second antenna array, and moving the antenna apparatus includes moving the first antenna array in a first arc and moving the second antenna array in a second arc, the first and second arcs having respective centers of curvature positioned between the center of the subject position and the respective antenna array.

97. A method according to claim **96**, further comprising moving the first antenna array between a distal position and a proximal position, the array being closer to the subject position when in the proximal position than when in the distal position.

98. A method according to claim **94**, in which the antenna apparatus includes a first antenna array and a second antenna array, and moving the antenna apparatus includes moving the first antenna array in a first arc and moving the second antenna array in a second arc, the first and second arcs having respective centers of curvature positioned between the center of the subject position and the respective antenna array.

99. A method according to claim **98**, further comprising moving the first antenna array between a distal position and a proximal position, the array being closer to the subject position when in the proximal position than when in the distal position.

100. A method according to claim **94**, in which the antenna apparatus includes at least one antenna unit, and moving the antenna apparatus includes pivoting each antenna unit about a pivot axis corresponding to the center of curvature of the curved locus of points, whereby each antenna unit scans across at least a portion of the subject position as the antenna unit pivots about the pivot axis.

101. A method according to claim **100**, in which pivoting each antenna unit includes pivoting each antenna unit about a fixed pivot axis.

102. A method according to claim **88**, in which moving the antenna apparatus includes moving the antenna apparatus along a curved locus of points having a center of

curvature on a side of the antenna apparatus opposite from the center of the subject position.

103. A method according to claim **102**, in which the antenna apparatus includes at least one antenna unit, and moving the antenna apparatus includes pivoting each antenna unit about a pivot axis corresponding to the center of curvature of the curved locus of points, whereby each antenna unit scans across at least a portion of the subject position as the antenna unit pivots about the pivot axis.

104. A method according to claim **103**, in which pivoting each antenna unit includes pivoting each antenna unit about a fixed pivot axis.

105. A method according to claim **86**, in which transmitting radiation includes transmitting radiation along a curved locus of points having a plurality of different centers of curvature.

106. A method according to claim **105**, in which transmitting radiation includes transmitting radiation along a locus of points having an intermediate curved portion and an end curved portion on each end of the intermediate curved portion, with the intermediate curved portion having a longer radius of curvature than the radius of curvature of the end portions.

107. A method according to claim **106**, in which transmitting radiation includes transmitting radiation from an antenna apparatus, and receiving radiation includes receiving information on an antenna apparatus, the method further comprising moving the antenna apparatus in a curved path along the end and intermediate curved portions of the locus of points during transmitting and receiving.

108. A method of imaging comprising:
transmitting from a transmission position spaced from a subject position toward a subject in the subject position, electromagnetic radiation in a frequency range of about 200 MHz to about 1 THz;
scanning the radiation transmitted from the transmission position across at least a portion of the subject position;
receiving from the subject reflected electromagnetic radiation;
producing an output representative of the received radiation; and
converting the output into image data representative of an image of at least a portion of the subject.

109. A method according to claim **108**, in which transmitting radiation includes transmitting radiation from at least one antenna unit, and scanning the radiation includes pivoting each antenna unit about a pivot axis.

110. A method according to claim **109**, in which pivoting each antenna unit includes pivoting each antenna unit about a fixed pivot axis.

111. A system of imaging comprising:
means for transmitting toward a subject in a subject position having a center, electromagnetic radiation in a frequency range of about 200 MHz to about 1 THz, from positions spaced from the subject position and distributed along a first locus of points including at least a first curved locus of points having a center of curvature spaced from the center of the subject position;
means for receiving from the subject reflected electromagnetic radiation;

means for producing an output representative of the received radiation; and

means for converting the output into image data representative of an image of at least a portion of the subject.

112. A system according to claim **111**, in which the means for transmitting radiation includes an antenna apparatus, and the means for receiving radiation includes the antenna apparatus, the system further comprising means for moving the antenna apparatus in a curved path along the curved locus of points during transmitting and receiving.

113. A system according to claim **112**, in which the means for moving the antenna apparatus is further for moving the antenna apparatus along a curved locus of points having a center of curvature on the opposite side of the center of the subject position from the antenna apparatus.

114. A system according to claim **112**, in which the means for moving the antenna apparatus is further for moving the antenna apparatus along a curved locus of points corresponding to a shape of a subject that is eccentric relative to the center of the subject position.

115. A system according to claim **112**, in which the means for moving the antenna apparatus is further for moving the antenna apparatus along a curved locus of points having a plurality of centers of curvature.

116. A system according to claim **112**, in which the means for moving the antenna apparatus is further for moving the antenna apparatus along a curved locus of points having a center of curvature on a side of the antenna apparatus opposite from the center of the subject position.

117. A system according to claim **116**, in which the antenna apparatus includes at least one antenna unit, and the means for moving the antenna apparatus is further for pivoting each antenna unit about a pivot axis corresponding to the center of curvature of the curved locus of points, whereby each antenna unit scans across at least a portion of the subject position as the antenna unit pivots about the pivot axis.

118. A system according to claim **111**, in which the means for transmitting radiation is further for transmitting radiation along a curved locus of points having a plurality of different centers of curvature.

119. A system of imaging comprising:
means for transmitting from a transmission position spaced from a subject position toward a subject in the subject position, electromagnetic radiation in a frequency range of about 200 MHz to about 1 THz;
means for scanning the radiation transmitted from the transmission position across at least a portion of the subject position;
means for receiving from the subject reflected electromagnetic radiation;
means for producing an output representative of the received radiation; and
means for converting the output into image data representative of an image of at least a portion of the subject.

120. A system according to claim **119**, in which the means for transmitting radiation is further for transmitting radiation from at least one antenna unit, and scanning the radiation includes pivoting each antenna unit about a pivot axis.